



CS 38-SL

Windows & Doors



CS 38-SL

Windows & Doors

R
REYNAERS
aluminium

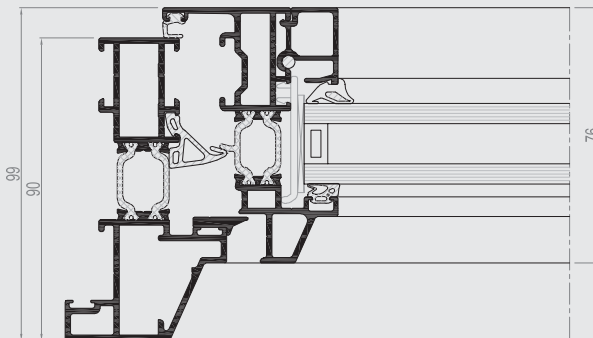
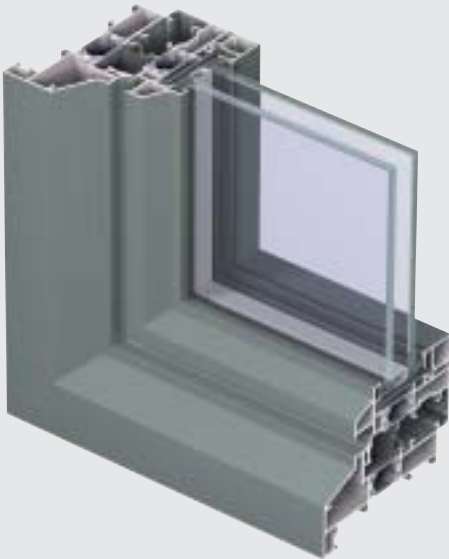

CS 38-SL is a thermally improved three-chamber system for windows and doors that combines ultimate elegance, elevated strength, energy efficiency and ease in production.

The system's slender exterior contours offer the ideal solution for new-build constructions as well as for the replacement of steel-framed windows and window-doors, respecting the original design. All types of inward and outward opening vents are available.

Different inner and outer colour possible.

TECHNICAL CHARACTERISTICS



Min. visible width inward opening window		
Frame		33 mm
Vent		23 mm
Min. visible width outward opening window		
Frame		29 mm
Vent		60 mm
Min. visible width inward opening window-door		
Frame		33 mm
Vent		53 mm
Min. visible width outward opening window-door		
Frame		33 mm
Vent		82 mm
Min. visible width T-profile		48 mm
Overall system depth window		
Frame		90 mm
Vent		76 mm
Rebate height		14 mm
Glass thickness		up to 44 mm
Glazing method		dry glazing with EPDM or neutral silicones
Thermal insulation		omega-shaped fibreglass reinforced polyamide strips (frame 23 mm - vent 22 mm)



PERFORMANCES

ENERGY

Thermal Insulation⁽¹⁾
EN 10077-2

Uf-value between 2.4 W/m²K and 3.1 W/m²K,
depending on the frame/vent combination

COMFORT

Acoustic performance⁽²⁾
EN ISO 140-3; EN ISO 717-1

Rw (C; Ctr) = 36 (-1; -4) dB / 45 (0; -3) dB, depending on glazing type

Air tightness, max. test pressure⁽³⁾
EN 1026; EN 12207

1 (150 Pa)	2 (300 Pa)	3 (600 Pa)	4 (600 Pa)
---------------	---------------	---------------	---------------

Water tightness⁽⁴⁾
EN 1027; EN 12208

1A (0 Pa)	2A (50 Pa)	3A (100 Pa)	4A (150 Pa)	5A (200 Pa)	6A (250 Pa)	7A (300 Pa)	8A (450 Pa)	9A (600 Pa)	E (750 Pa)
--------------	---------------	----------------	----------------	----------------	----------------	----------------	----------------	----------------	---------------

Wind load resistance,
max. test pressure⁽⁵⁾
EN 12211; EN 12210

1 (400 Pa)	2 (800 Pa)	3 (1200 Pa)	4 (1600 Pa)	5 (2000 Pa)	E _{xxx} (> 2000 Pa)
---------------	---------------	----------------	----------------	----------------	---------------------------------

Wind load resistance to frame
deflection⁽⁵⁾
EN 12211; EN 12210

A (≤1/150)	B (≤1/200)	C (≤1/300)
---------------	---------------	---------------

SAFETY

Burglar resistance⁽⁶⁾
ENV 1627 - ENV 1630

WK 1	WK 2 (windows)	WK 3
------	-------------------	------

This table shows possible classes and values of performances. The values indicated in red are the ones relevant to this system.

(1) The Uf-value measures the heat flow. The lower the Uf-value, the better the thermal insulation of the frame.

(2) The sound reduction index (Rw) measures the capacity of the sound reduction performance of the frame.

(3) The air tightness test measures the volume of air that would pass through a closed window at a certain air pressure.

(4) The water tightness testing involves applying a uniform water spray at increasing air pressure until water penetrates the window.

(5) The wind load resistance is a measure of the profile's structural strength and is tested by applying increasing levels of air pressure to simulate the wind force. There are up to five levels of wind resistance (1 to 5) and three deflection classes (A,B,C). The higher the number, the better the performance.

(6) The burglar resistance is tested by statistical and dynamic loads, as well as by simulated attempts to break in using specified tools.



For more information about our products and services please call, fax or email and we will respond immediately.

A Plus Aluminium . Moor Park Industrial Centre . Tolpits Lane
Watford . Hertfordshire . WD18 9EZ
T: +44 01923 22 58 55 . F: +44 01923 25 61 06
E: enquiries@apluswindows.co.uk . W: www.apluswindows.co.uk



Certificate No. FM 533422



A Plus Aluminium is a trading name of A Plus Windows and Doors Limited.
The accreditation shown above have been awarded to A Plus Windows & Doors Limited.

